

Gas Discharge Tube: GC8 Series



2-Electrode $\Phi 8 \times T8$ mm High Voltage Type

■ Features

1. RoHS & HF compliant
2. Rugged ceramic-metal construction
3. Available with or without leads
4. DC spark-over voltage: 600~3500V
5. Low capacitance
6. Agency recognition: UL / cUL
7. Operating temperature: $-40^{\circ}\text{C} \sim +105^{\circ}\text{C}$
Storage temperature: $-40^{\circ}\text{C} \sim +115^{\circ}\text{C}$



■ Recommended Applications

1. Modem
2. xDSL splitter
3. CATV system
4. Power supply
5. Consumer electronics
6. Communication lines

■ Part Number Code

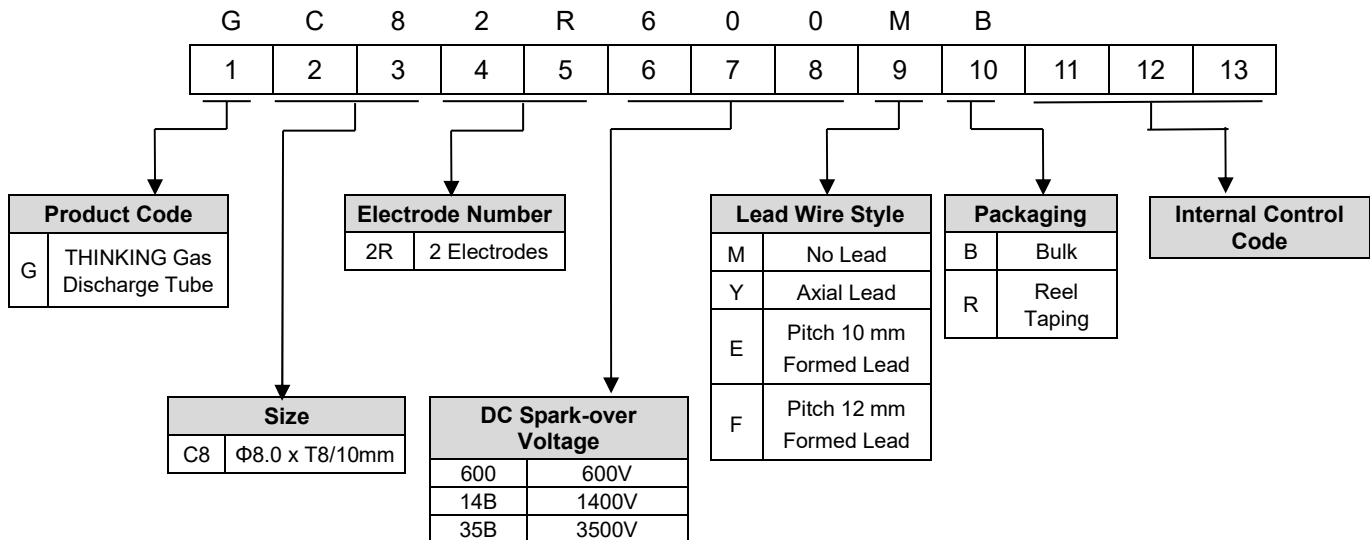

Gas Discharge Tube: GC8 Series



2-Electrode $\Phi 8 \times T 8$ mm High Voltage Type

■ Characteristics

Part No.	DC Spark-over Voltage	Max. Impulse Breakdown Voltage		Max. Impulse Discharge Current (8/20 μ s)		Impulse Life (10/1000 μ s)	Normal Alternating Discharge Current	Minimum Insulation Resistance	Maximum Capacitance (1MHz)	Safety Approvals
	100V/S	100V/ μ s	1KV/ μ s	1 time	10 times	100A	50Hz, 1Sec			
	(V)	(V)	(V)	(KA)		(Times)	(A)			
GC82R600□□	600 \pm 20%	1000	1100	8	5	100	5	1	1.5	√
GC82R800□□	800 \pm 20%	1100	1200							√
GC82R10B□□	1000 \pm 20%	1300	1400							√
GC82R14B□□	1400 \pm 20%	2100	2200							√
GC82R16B□□	1600 \pm 20%	2300	2400							√
GC82R20B□□	2000 \pm 20%	2700	2800							√
GC82R25B□□	2500 \pm 20%	3500	3600							√
GC82R27B□□	2700 \pm 20%	3600	3800	5	3	300*	3	1	1.5	√
GC82R30B□□	3000 \pm 20%	4100	4200							√
GC82R35B□□	3500 \pm 20%	4900	5000							100*

Note1: The first □ is style of lead wire, and the second □ is packaging.

Note2: * means products measured with an 8/20us waveform, 100A

Note3: UL 1449 4th File No: E314979

Note4: Insulation resistance test conditions:

DC Spark-over Voltage	DC Measuring Voltage
70-150V	50V
151-400V	100V
401-1000V	250V
1001-2000V	500V
>2001V	1000V

Gas Discharge Tube: GC8 Series



2-Electrode $\Phi 8 \times T 8$ mm High Voltage Type

Dimension

(Unit: mm)

□ = Y (Axial Lead Type)

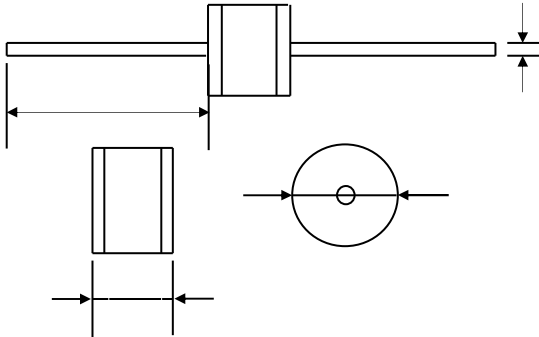

Item	Dimensions	
	Spec.	Tolerance
D	8.0	+0.3/-0.5
T	8.0	+0.6/-0.1
L	20	Min.
d	0.8	± 0.05

□ = M (No Lead Type)

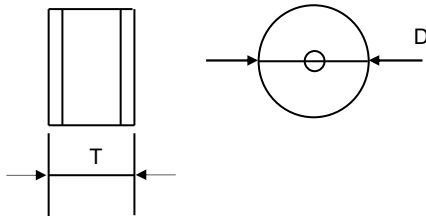

(Unit: mm)

Item	Dimensions	
	Spec.	Tolerance
D	8.0	+0.3/-0.5
T	8.0	+0.6/-0.1

□ = E (Formed Lead)

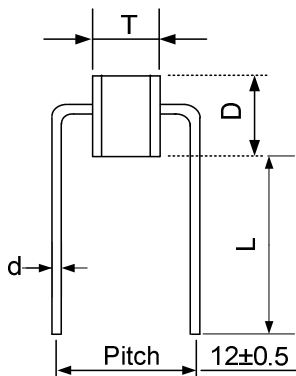

(Unit: mm)

Item	Dimensions	
	Spec.	Tolerance
D	8.0	+0.3/-0.5
T	8.0	+0.6/-0.1
d	0.8	± 0.05
L	15.0	Min.
P	10.0	± 0.5

Gas Discharge Tube: GC8 Series



2-Electrode $\Phi 8 \times T 8$ mm High Voltage Type

□ = F (Formed Lead)

(Unit: mm)

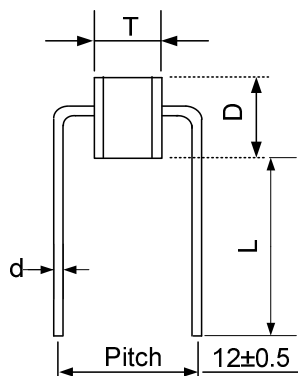

Item	Dimensions	
	Spec	Tolerance
D	8.0	+0.3/-0.5
T	8.0	+0.6/-0.1
d	0.8	±0.05
L	15.0	Min.
P	12	±0.5

■ Marking

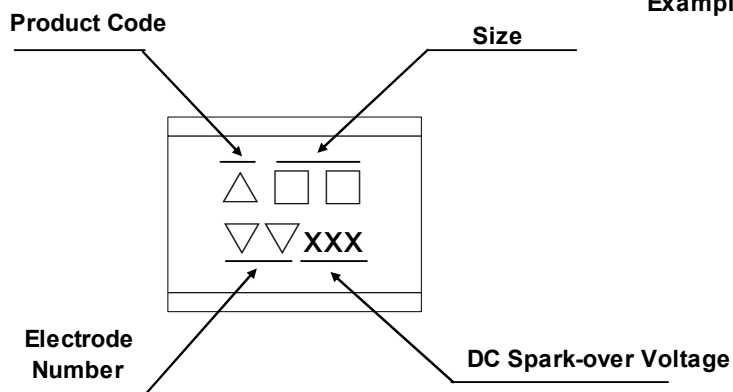

Example

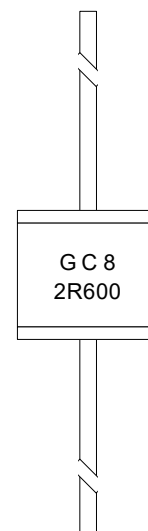
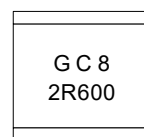

Gas Discharge Tube: GC8 Series

2-Electrode $\Phi 8 \times T 8$ mm High Voltage Type



Packaging

- Bulk

- ◆ For 8x8mm Axial Lead (Y Type):

Quantity: 100pcs per PVC Box, 500pcs per Inner Box

Quantity (MPQ): 500pcs

- ◆ For 8x8mm No Lead (M Type) :

Quantity: 100pcs per PVC Box, 500pcs per Inner Box

Quantity (MPQ): 500pcs

- ◆ For 8x8mm Formed Lead (E or F Type) :

Quantity: 100pcs per PVC Box, 500pcs per Inner Box

Quantity (MPQ): 500pcs

Gas Discharge Tube: GC8 Series



2-Electrode $\Phi 8 \times T 8$ mm High Voltage Type

● Taping

For 2-electrode Axial Lead GDT: 500 PCS/Reel

Quantity (MPQ): 500pcs

(Unit: mm)

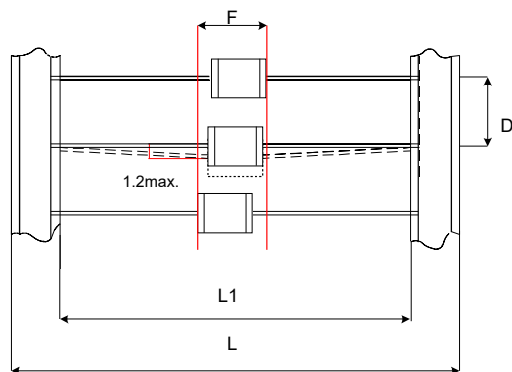

Item	Dimensions	
	Spec.	Tolerance
L1	52	± 2
L	64	± 3
D	10	± 0.5
F	$T + 1.4$	Max.

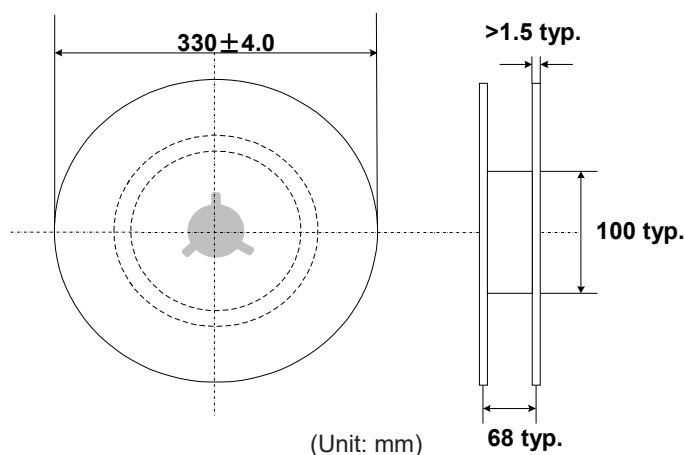

■ Warehouse Storage Conditions of Products

● Storage Conditions:

1. Storage Temperature: $-10^{\circ}\text{C} \sim +40^{\circ}\text{C}$
2. Relative Humidity: $\leq 75\% \text{RH}$
3. Keep away from corrosive atmosphere and sunlight.

● Period of Storage: 1 year